

# HTI-UC325

## 1080P USB Camera



- Max.25/30fps@1080P
- Auto-focus
- Built-in microphone, 3 meters pickup distance
- USB connection & easy operation
- UVC protocol & high compatibility

### Product Overview

HTI-UC325 is a 1080P HD USB camera that provides a professional-quality video and audio experience for users. It not only equips with best-in-class camera whose horizontal field of view is up to 84.5°, but also integrates built-in omnidirectional microphone that can clearly pick up audio from up to 3 meters away. Moreover, it supports auto focus, ensuring people can be seen clearly in all the video meetings. HTI-UC325 can work with mainstream video conferencing platforms, providing high compatibility and seamless integration for people in both business and life scenarios.

### Technical Specification

#### Camera

Sensor Type	1/2.8 inch CMOS, 2M pixel
Video Format	1080p@30fps/25fps/20fps/15fps/10fps/5fps, 720p@30fps/25fps/20fps/15fps/10fps/5fps, 480P@30fps/25fps/20fps/15fps/10fps/5fps, 320x240p@30fps/25fps/20fps/15fps/10fps/5fps
Compression	H.265/H.264/MJPEG/YUV
UVC Protocol	UVC1.0/1.1/1.5
Focal Length	3.0 mm±5%
Focus	Auto
Horizontal Field of View	84.5°
Exposure	Auto, BLC/HLC
Shutter Speed	1/30s ~ 1/10000s
Digital Noise Reduction	2D & 3D Digital Noise Reduction
SNR	≥38dB

White Balance	Auto
Microphone	
Position	Built-in
Pickup Distance	Omnidirectional, Pickup Distance Up to 3m
General	
Video Interface	1 * USB2.0
Working Status Indicator	Power-on/Power-off
Privacy Shade	Support
Power Supply	USB 5V
Input Current	200mA
Power Consumption	Max 1W
Working Temperature	0°~+60°
Working Humidity	< 95% (Noncondensing)
MTBF	30000H

#### System Requirements

OS	Windows® 7, Windows 8.1, Windows 10 or Higher macOS™ 10.10 or Higher Google™ Chromebook™ Version 29.0.1547.70 or Higher Linu × (UVC Protocol Required)
Hardware	2.4 GHz Intel® Core 2 Duo CPU or Higher 2 GB Memory or Higher USB 2.0 Interface

Dimensions (mm[inch])

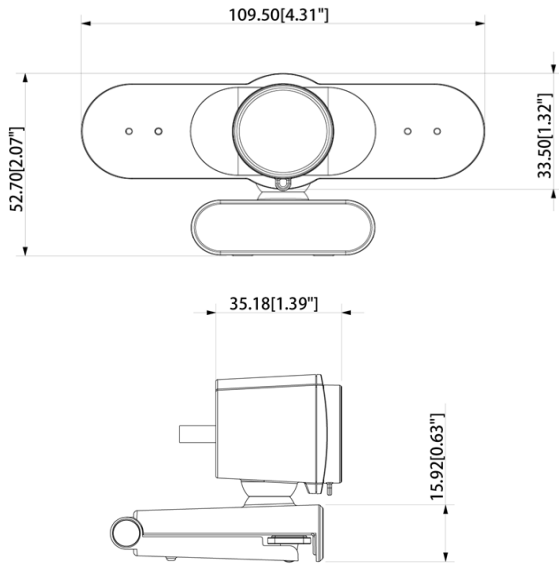

Installation

