



Ruijie RG-RAP62-Wall Access Point

Installation Guide

Copyright

Copyright © 2025 Ruijie Networks

All rights are reserved in this document and this statement.

Without the prior written consent of Ruijie Networks, no organization or individual is permitted to reproduce, extract, back up, modify, or distribute the content of this document in any manner or form. It is also prohibited to translate the document into other languages or use any or all parts of it for commercial purposes.

 and  trademarks are owned by Ruijie Networks.

All other trademarks or registered trademarks mentioned in this document are owned by their respective owners.

Disclaimer

The products, services, or features that you purchase are subject to commercial contracts and terms. It is possible that some or all of the products, services, or features described in this document may not be available for purchase or use. Unless agreed upon otherwise in the contract, Ruijie Networks does not provide any explicit or implicit statements or warranties regarding the content of this document.

The names, links, descriptions, screenshots, and any other information regarding third-party software mentioned in this document are provided for your reference only. Ruijie Networks does not explicitly or implicitly endorse or recommend the use of any third-party software and does not make any assurances or guarantees concerning the applicability, security, or legality of such software. You should choose and use third-party software based on your business requirements and obtain proper authorization. Ruijie Networks assumes no liability for any risks or damages arising from your use of third-party software.

The content of this document is subject to constant change due to product version upgrades or other reasons. Thus, Ruijie Networks reserves the right to modify the content of the document without prior notice or prompt.

This manual serves solely as a user guide. While Ruijie Networks endeavors to ensure the accuracy and reliability of the content when compiling this manual, it does not guarantee that the content of the manual is free of errors or omissions. All information contained in this manual does not constitute any explicit or implicit warranties.

Personal Data Statement

During the operation or troubleshooting of the products, services, or features you have purchased, certain personal data of users may be collected or used. Therefore, it is essential for you to establish and implement appropriate privacy policies, in compliance with the relevant laws and regulations of the applicable countries or regions, to ensure the complete protection of users' personal data.

If Ruijie Networks is involved in this process, we will strictly adhere to the relevant laws and regulations of the applicable countries or regions and take all necessary actions to safeguard users' personal data.

When discarding, reclaiming, or reusing a device, please ensure to back up or clear any stored data to avoid data leakage. For assistance, please contact our after-sales technical support.

Preface

Intended Audience

This document is intended for:

- Network engineers
- Technical support and servicing engineers
- Network administrators

Technical Support

- Ruijie Networks website: <https://www.ruijie.com>
- Online support center: <https://www.ruijie.com/support>
- Case portal: <https://caseportal.ruijie.com>
- Community: <https://community.ruijienetworks.com>
- Email support: service_rj@ruijie.com
- Live chat: <https://www.ruijie.com/rita>
- Documentation feedback: doc@ruijie.com.cn

Conventions

1. Signs

The signs used in this document are described as follows:

 **Danger**
An alert that contains important safety instructions. Before you work on any equipment, be aware of the hazards involved and be familiar with standard practices in case of accidents.

 **Warning**
An alert that calls attention to important rules and information that if not understood or followed can result in data loss or equipment damage.

 **Caution**
An alert that calls attention to essential information that if not understood or followed can result in function failure or performance degradation.

 **Note**
An alert that contains additional or supplementary information that if not understood or followed will not lead to serious consequences.

 **Specification**
An alert that contains a description of product or version support.

2. Note

The manual provides configuration information, including models, port types, and command line interfaces, for reference purposes only. In the event of any discrepancy or inconsistency between the manual and the actual version, the actual version shall take precedence.

Contents

Preface	1
1 Overview	1
1.1 About the RG-RAP62-Wall	1
1.2 Package Contents.....	1
1.3 Product Appearance	2
1.3.1 Front Panel.....	2
1.3.2 Rear Panel	4
1.3.3 Top and Bottom	4
1.4 Technical Specifications	5
1.5 Technical Specifications of Power Supply.....	7
1.6 Cooling.....	7
2 Preparing for Installation	8
2.1 Safety Guidelines.....	8
2.1.1 General Precautions	8
2.1.2 Handling Safety.....	8
2.1.3 Electricity Safety	8
2.2 Site Requirements	9
2.2.1 Bearing.....	9
2.2.2 Ventilation.....	9
2.2.3 Temperature and Humidity.....	9
2.2.4 Cleanliness.....	9
2.2.5 Grounding	10

2.2.6 Electromagnetic Interference.....	10
2.3 Tools	11
3 Installing the AP.....	12
3.1 Before You Begin.....	12
3.2 Precautions	12
3.3 Installing the Equipment	12
3.4 Removing the Equipment	16
3.5 Bundling up Cables.....	17
3.6 Checklist After Installation	17
4 Verifying Operating Status	19
4.1 Setting Up the Configuration Environment.....	19
4.2 Powering on the AP	19
4.2.1 Checklist Before Power-on	19
4.2.2 Checklist After Power-on	19
4.3 Rectifying Power Supply Failures.....	19
5 Monitoring and Maintenance.....	20
5.1 Monitoring	20
5.2 Maintenance	20
6 Common Troubleshooting.....	21
6.1 General Troubleshooting Flowchart	21
6.2 Common Faults.....	22
7 Appendix.....	23
7.1 Connectors and Media.....	23
7.1.1 10/100/1000BASE-T Port	23

7.2 Cabling Recommendations.....24

1 Overview

1.1 About the RG-RAP62-Wall

The RG-RAP62-Wall is a Gigabit dual-band wall-plate Wi-Fi 6 access point (AP) designed for small- or medium-sized indoor scenarios covering hotels, apartments, villas, residential buildings, and small offices. Compliant with the IEEE 802.11ax, IEEE 802.11ac Wave 1/Wave 2, and IEEE 802.11a/b/g/n standards, as well as dual-stream Multi-User Multiple-Input Multiple-Output (MU-MIMO) technology, the RG-RAP62-Wall can operate in the 2.4 GHz and 5 GHz frequency bands simultaneously, delivering an access rate of up to 573 Mbps in the 2.4 GHz frequency band and 2401 Mbps in the 5 GHz frequency band. The AP provides a wireless access rate of up to 2974 Mbps. It also provides four 1 Gigabit Ethernet ports for wired connection, catering to the indoor wired and wireless dual-gigabit deployment requirements.

The RG-RAP62-Wall can be mounted in junction boxes of various standards: Chinese standard (86 mm x 86 mm), European standard (86 mm x 86 mm), South African standard (114 mm x 114 mm), and US standard (108 mm x 59 mm), making it highly versatile for different installation environments.

1.2 Package Contents

Table 1-1 Package Contents

No.	Item	Quantity
1	RG-RAP62-Wall access point (with a decorative cover)	1
2	User Manual	1
3	Warranty Card	1
4	Mounting bracket	1
5	Lock key	1
6	M4 x 40 mm machine screw	2
7	M3.5 x 30 mm machine screw	2
8	ST3 x 30 mm tapping screw	2

Note

The package contents are subject to the purchase contract, and actual delivery may vary. Please check the items carefully against the package contents or purchase contract. If you have any questions, please contact the distributor.

1.3 Product Appearance

Figure 1-1 Appearance

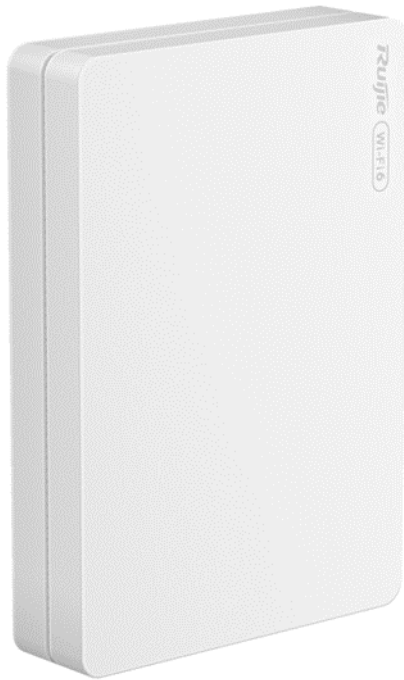

1.3.1 Front Panel

Figure 1-2 Front Panel

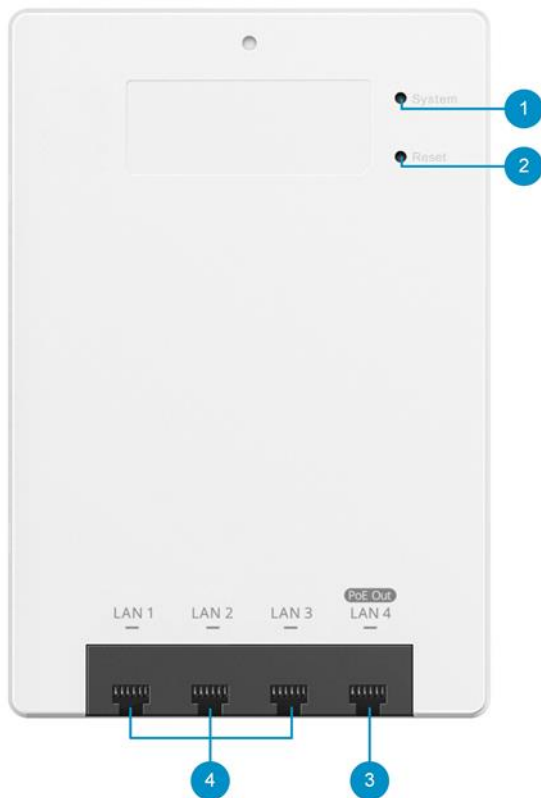



Table 1-2 Components on the Front Panel

No.	Component	Description
2	Reset button	The operation is as follows: <ul style="list-style-type: none"> ● Press and hold the button for less than 2 seconds: Restart the AP. ● Press and hold the button for more than 5 seconds: Restore the AP to factory settings. Then, you can log in to the device's eWeb using the default IP address and password (10.44.77.254/admin).
3	LAN 4 port	1 x 10/100/1000BASE-T port, which is connected to a wired device and supports PoE Out.
4	LAN 1 to LAN 3 ports	3 x 10/100/1000BASE-T ports, which are connected to wired devices.

Table 1-3 LEDs

No.	Component	Description
1	System status LED	Off: <ul style="list-style-type: none"> ● The AP is not powered on. ● The LED is manually turned off.
		Solid white: The AP is operating properly without any alarms.
		Fast blinking white: <ul style="list-style-type: none"> ● The AP is starting up. ● The AP is restarting.
		Slow blinking white: <ul style="list-style-type: none"> ● The AP is resetting. ● The AP is upgrading.
		 Caution Do not power off the AP when the LED is in this state.
		One long blink (white) followed by three slow blinks (white): The AP is recovering.
		One long blink (white) followed by one slow blink (white): The AP has insufficient PoE power.
		Solid white and fast off: The AP is not connected to Ruijie Cloud.
		Fast blinking white for 3s and then off for 3s: The AP is being located through Ruijie Reyee App.
		LED blinking patterns: <ul style="list-style-type: none"> ● Long blinking: The LED blinks once every two seconds. ● Fast blinking: The LED blinks eight times every second.

No.	Component	Description
●	Slow blinking:	The LED blinks twice every second.
●	Solid on and fast off:	The LED is solid on and fast off once every two seconds.

1.3.2 Rear Panel

Figure 1-3 Rear Panel

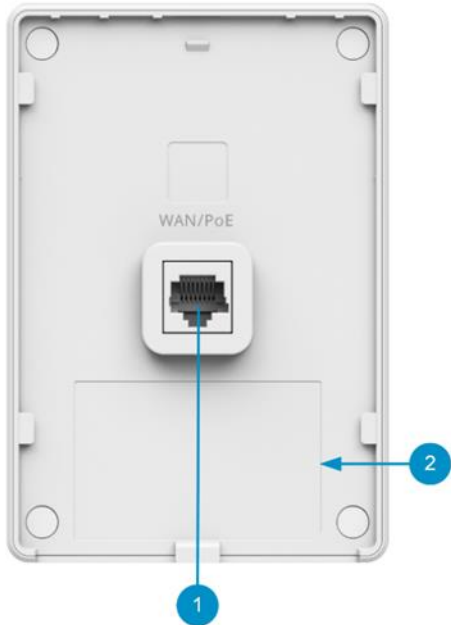

Table 1-4 Components on the Rear Panel

No.	Component	Description
1	WAN/PoE port	10/100/1000BASE-T port, which supports PoE In.
2	Nameplate	It is located on the rear panel.

1.3.3 Top and Bottom

Figure 1-4 Top and Bottom



Table 1-5 Components on the Top and Bottom

No.	Component	Description
1	Anti-theft lock	It enhances device security.
2	Reserved slot	To remove the decorative cover, you need to insert the delivered anti-theft lock key into the slot.

1.4 Technical Specifications

Table 1-6 Technical Specifications

Radio Design	Dual-band, two spatial streams
Wi-Fi Standard	IEEE 802.11ax, IEEE 802.11ac Wave 1 and Wave 2, and IEEE 802.11a/b/g/n
Operating Band	IEEE 802.11b/g/n/ax: 2.4 GHz to 2.4835 GHz IEEE 802.11a/n/ac/ax: 5.150 GHz to 5.350 GHz, 5.470 GHz to 5.725 GHz, and 5.725 GHz to 5.850 GHz
Antenna	Built-in omnidirectional antennas (2.4 GHz: 4.08 dBi; 5 GHz: 5.40 dBi)
Spatial Stream	2.4 GHz: 2x2 MU-MIMO 5 GHz: 2x2 MU-MIMO
Data Rate	2.4 GHz: 573 Mbps 5 GHz: 2401 Mbps Maximum wireless data rate: 2974 Mbps
Modulation	OFDM: BPSK @ 6/9 Mbps, QPSK @ 12/18 Mbps, 16QAM @ 24 Mbps, 64QAM @ 48/54 Mbps DSSS: DBPSK @ 1 Mbps, DQPSK @ 2 Mbps, and CCK @ 5.5/11 Mbps MIMO-OFDM: BPSK, QPSK, 16QAM, 64QAM, 256QAM and 1024QAM OFDMA
Receive Sensitivity	802.11b: -91 dBm (1 Mbps), -88 dBm (5.5 Mbps), -85 dBm (11 Mbps) 802.11a/g: -89 dBm (6 Mbps), -80 dBm (24 Mbps), -76 dBm (36 Mbps), -71 dBm (54 Mbps) 802.11n: -83 dBm (MCS0), -65 dBm (MCS7), -83 dBm (MCS8), -65 dBm (MCS15) 802.11ac: 20 MHz: -83 dBm (MCS0), -57 dBm (MCS9) 802.11ac: 40 MHz: -79 dBm (MCS0), -57 dBm (MCS9) 802.11ac: 80 MHz: -76 dBm (MCS0), -51 dBm (MCS9) 802.11ac: 160 MHz: -76 dBm (MCS0), -50 dBm (MCS9) 802.11ax: 20 MHz: -85 dBm (MCS0), -58 dBm (MCS11)

	<p>802.11ax: 40 MHz: -82 dBm (MCS0), -54 dBm (MCS11)</p> <p>802.11ax: 80 MHz: -79 dBm (MCS0), -52 dBm (MCS11)</p> <p>802.11ax: 160 MHz: -76 dBm (MCS0), -49 dBm (MCS11)</p>
Maximum Transmit Power	<p>2.4 GHz, Combined power: 21 dBm (single-stream power: 18 dBm)</p> <p>5 GHz, Combined power: 21 dBm (single-stream power: 18 dBm)</p> <hr/> <p>Note</p> <p>The transmit power varies according to regulations in different countries and regions.</p> <hr/> <p>Frequency bands using and the max EIRP.</p> <hr/> <p>Note</p> <p>Country specific restrictions apply.</p> <hr/> <ul style="list-style-type: none"> ● European Union & United Kingdom: <ul style="list-style-type: none"> ○ 2400 MHz to 2483.5 MHz, EIRP ≤ 20 dBm ○ 5150 MHz to 5350 MHz, EIRP ≤ 23 dBm ○ 5470 MHz to 5725 MHz, EIRP ≤ 30 dBm ● Myanmar: <ul style="list-style-type: none"> ○ 2400 MHz to 2483.5 MHz, EIRP ≤ 23 dBm ○ 5725 MHz to 5825 MHz, EIRP ≤ 30 dBm ● Thailand: <ul style="list-style-type: none"> ○ 2400 MHz to 2483.5 MHz, EIRP ≤ 20 dBm ○ 5150 MHz to 5350 MHz, EIRP ≤ 23 dBm ○ 5470 MHz to 5725 MHz, EIRP ≤ 30 dBm ○ 5725 MHz to 5825 MHz, EIRP ≤ 30 dBm ● Indonesia: <ul style="list-style-type: none"> ○ 2400 MHz to 2483.5 MHz, EIRP ≤ 27 dBm ○ 5150 MHz to 5350 MHz, EIRP ≤ 23 dBm ○ 5725 MHz to 5825 MHz, EIRP ≤ 23 dBm ● Egypt: <ul style="list-style-type: none"> ○ 2400 MHz to 2483.5 MHz, EIRP ≤ 20 dBm ○ 5150 MHz to 5350 MHz, EIRP ≤ 23 dBm
Adjustable Power Granularity	1 dBm
Product Dimensions (W x D x H)	86 mm x 23.5 mm x 125 mm (3.39 in. x 0.93 in. x 4.92 in.) (The height indicates the distance that the AP protrudes from the wall once installed.)
Weight	≤ 0.33 kg (0.73 lbs., excluding packaging materials)
Shipping Weight	≤ 0.43 kg (0.95 lbs.)

Service Ports	<ul style="list-style-type: none"> ● 1 x 10/100/1000BASE-T uplink port, which supports PoE In. ● 4 x 10/100/1000BASE-T downlink ports, which are connected to wired clients. LAN 4 supports PoE Out.
LED	1 x system status LED
Power Supply	IEEE 802.3at compliant PoE+ (Under normal operation. The PoE Output function is enabled for LAN4 port and the maximum power output is 10 W.), compatible with IEEE 802.3af compliant PoE (the PoE Out function of LAN4 port is disabled when IEEE 802.3af compliant PoE is used.).
Maximum Power Consumption	12 W (when the PoE Output of the LAN 4 port is disabled.)
Operating Temperature	0°C to 40°C (32°F to 104°F)
Operating Humidity	5% RH to 95% RH (non-condensing)
Storage Temperature	-40°C to +70°C (-40°F to +158°F)
Storage Humidity	5% RH to 95% RH (non-condensing)
Mounting Option	Junction box
Color	White
Certification	CE, CB
MTBF	> 400,000 hours

1.5 Technical Specifications of Power Supply

The RG-RAP62-Wall adopts PoE input and is compliant with IEEE 802.3af and IEEE 802.3at (The PoE Out function of the LAN 4 port is disabled when the IEEE 802.3af-compliant PoE power supply is used.)

When PoE is used, ensure that the power sourcing equipment (PSE) is at least IEEE 802.3af-compliant. For optimal device performance, it is recommended that a PSE that complies with IEEE 802.3at should be used. Alternatively, you are advised to use a PoE adapter certified by Ruijie.

1.6 Cooling

The RG-RAP62-Wall adopts the fanless design. Therefore, when installing the AP, ensure that there is sufficient clearance around the AP for heat dissipation.

2 Preparing for Installation

2.1 Safety Guidelines

Note

- To avoid personal injury and equipment damage, carefully read the safety precautions before you install the equipment.
 - The following safety guidelines may not include all the potentially hazardous situations.
-

2.1.1 General Precautions

- Do not expose the equipment to high temperatures, dust, or harmful gases. Do not install the equipment in flammable or explosive environments. Keep the equipment away from sources of electromagnetic interference (EMI), such as large radar stations, radio stations, and substations. Do not subject the equipment to unstable voltage, vibration, or excessive noise.
 - The installation site should be dry. Do not install the equipment in a place near the sea. Keep the equipment at least 500 m (1640.42 ft.) away from the ocean and do not face it towards the sea breeze.
 - The installation site should be free from water flooding, seepage, dripping, or condensation. The installation site should be selected according to network planning and communications equipment features, and considerations such as climate, hydrology, geology, earthquake, electrical power, and transportation.
 - Ensure that the equipment and power distribution system are properly grounded.
-

Caution

Follow the procedures in the user manual to install and remove the equipment.

2.1.2 Handling Safety

- Avoid moving the equipment frequently.
- Cut off all power supplies and disconnect all cables before lifting or moving the equipment.

2.1.3 Electricity Safety

Warning

- Any deviation from standard or improper electrical operations can result in accidents such as fires or electric shocks, potentially causing severe or even fatal harm to both individuals and equipment.
 - Direct or indirect touch through a wet object on high-voltage and mains supply can bring a fatal danger.
-

- Always observe the local regulations and standards. Only qualified personnel should be allowed to operate the equipment.
- Check whether there are potential risks in the working area. For example, check whether the grounding is reliable, and whether the ground is wet.
- Locate the emergency power-off switch in the room before installation. In the case of an accident, cut off the

power supply immediately.

- Check the equipment carefully before shutting down the power supply.
- Keep the equipment far away from the grounding facility and lightning protection facility of the power equipment.
- Keep the equipment away from radio stations, radar stations, high-frequency and high-current equipment, microwave ovens, and other high-power wireless equipment.

2.2 Site Requirements

The RG-RAP62-Wall must be installed and used indoors. For normal operation and prolonged service life of the equipment, the installation site must meet the following requirements.

2.2.1 Bearing

Evaluate the weight of the equipment and its accessories, and ensure that the installation site (such as a wall) can bear the weight.

2.2.2 Ventilation

The equipment adopts natural cooling. Reserve a sufficient clearance around the equipment to ensure proper ventilation.

2.2.3 Temperature and Humidity

To ensure the normal operation and prolonged service life of the equipment, maintain appropriate temperature and humidity in the equipment room. Working in an environment with too high or too low temperature and humidity for a long period may damage the equipment.

- In an environment with high relative humidity, insulating materials are prone to poor insulation or even electricity leakage.
- In an environment with low relative humidity, insulating gaskets may shrink, resulting in screw loosening.
- In a dry environment, static electricity is more likely to occur, posing a risk to the internal circuits of equipment.
- A high temperature can accelerate the aging process of insulation materials, greatly reducing the availability of the equipment and severely affecting its service life.

Table 2-1 Temperature and Humidity Requirements

Operating Temperature	Operating Humidity
0°C to 40°C (32°F to +104°F)	5% to 95%

2.2.4 Cleanliness

Dust poses a major threat to the equipment. The indoor dust can cause electrostatic adhesion when falling on the equipment, causing poor contact of the metallic joint. Such electrostatic adhesion occurs more easily when the indoor relative humidity is low, not only affecting the service life of the equipment, but also causing

communication failure easily. The following table lists the requirements for the dust content and diameter in the equipment room.

Table 2-2 Dust and Particles

Particle Diameter	Unit	Concentration
≥ 0.5 μm	Particles/m ³	≤ 1.4 × 10 ⁷
≥ 1 μm	Particles/m ³	≤ 7 × 10 ⁵
≥ 3 μm	Particles/m ³	≤ 2.4 × 10 ⁵
≥ 5 μm	Particles/m ³	≤ 1.3 × 10 ⁵

Apart from dust, the salt, acid, and sulfide in the air of the equipment room must meet strict requirements. These harmful substances will accelerate metal corrosion and component aging. The equipment room should be protected from harmful gases (such as sulfur dioxide, hydrogen sulfide, nitrogen dioxide, ammonia, and chlorine). The following table lists the limits of harmful gases in the equipment room.

Table 2-3 Hazardous Gases

Gas	Average (mg/m ³)	Maximum (mg/m ³)
Sulfur dioxide (SO ₂)	0.2	1.5
Hydrogen sulfide (H ₂ S)	0.006	0.03
Nitrogen dioxide (NO ₂)	0.04	0.15
Ammonia gas (NH ₃)	0.05	0.15
Chlorine gas (Cl ₂)	0.01	0.3

Note

The average value is measured over one week. The maximum value is the upper limit of the harmful gas measured in one week for up to 30 minutes every day.

2.2.5 Grounding

A proper grounding system is the basis for stable and reliable running and is indispensable for preventing lightning strikes and interference. Carefully check the grounding conditions at the installation site according to the grounding specifications, and complete grounding properly based on the actual situation.

2.2.6 Electromagnetic Interference

- Keep the AP away from grounding or lightning protection devices for power equipment.
- Keep the AP away from radio stations, radar stations, high-frequency high-current equipment, microwave ovens, and other high-power wireless equipment.

2.3 Tools

Table 2-4 Tools

Common Tools	Phillips screwdriver, cables, Ethernet cables, diagonal pliers, and cable ties
Special Tools	ESD-preventive gloves, wire stripper, crimping pliers, RJ45 crimping pliers, wire cutter, and waterproof tape
Meters	Multimeter

 **Note**

The equipment is delivered without a toolkit. Prepare the preceding tools by yourself.

3 Installing the AP

⚠ Caution

Before installing the equipment, ensure that guidelines and requirements in Chapter 2 have been met.

3.1 Before You Begin

Carefully plan and arrange the installation position, networking mode, power supply, and cabling before installation. Confirm the following requirements before installation:

- The installation site should provide sufficient space for heat dissipation.
- The installation site meets the temperature and humidity requirements of the equipment.
- The power supply is available at the installation site, and its current meets the requirements.
- The power supply meets the requirements.
- The installation site meets the cabling requirements of the equipment.
- The installation site meets the site requirements of the equipment.
- The customized equipment meets the client-specific requirements.

3.2 Precautions

To ensure the normal operation and prolonged service life of the AP, observe the following safety precautions:

- Do not power on the equipment during installation.
- Place the equipment in a well-ventilated environment.
- Do not subject the equipment to high temperatures.
- Keep the equipment away from high-voltage power cables.
- Do not expose the equipment to a thunderstorm or strong electric field.
- Cut off the power supply before cleaning the equipment.
- Do not open the enclosure when the equipment is working.
- Secure the equipment properly.

3.3 Installing the Equipment

⚠ Caution

- This installation guidance is for reference only. The actual installation process may differ depending on the specific physical product.
 - The package contains three pairs of screws of different specifications. Select one pair of screws to install the equipment based on the actual installation scenario.
-

The following figure shows the mounting bracket dimensions.

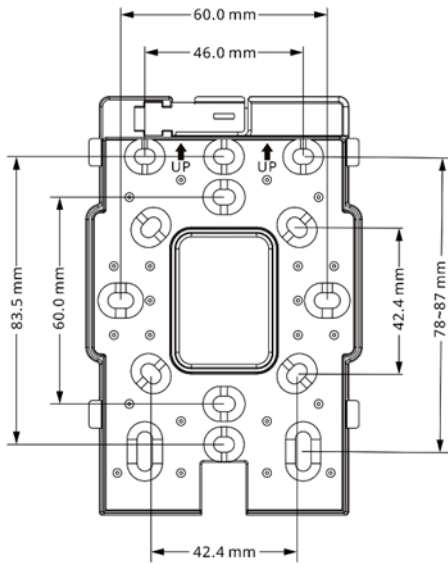

The AP can be installed on various junction boxes, including Chinese-standard and European-standard 86 mm junction boxes, American-standard 118 mm junction boxes, and South African-standard 120 mm junction boxes. To mount the AP on a Chinese-standard 86 mm junction box, follow these steps:

- (1) Remove the front panel of the 86 mm junction box on the wall.

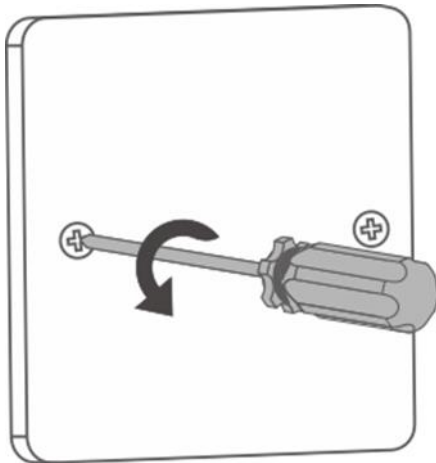

- (2) Use the screws delivered with the equipment to secure the mounting bracket to the junction box.

- o Chinese-standard 86 mm x 86 mm junction box:

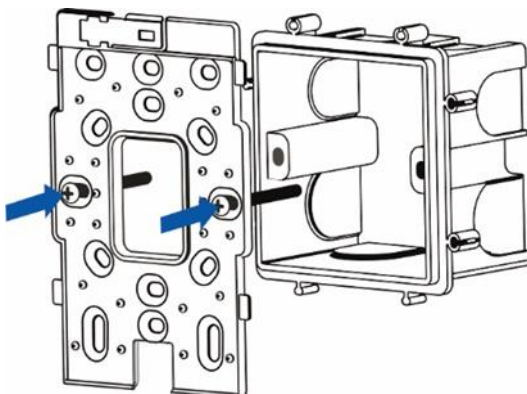

The following are brackets on a European-standard 86 mm x 86 mm junction box, a South African-standard 114 mm x 114 mm junction box, and an American-standard 108 mm x 59 mm junction box. The AP can be mounted horizontally or vertically on a South African-standard junction box.

- o European-standard 86 mm x 86 mm junction box. Select two hole positions to install screws:

Note

If more than two screws are required, prepare them by yourself.

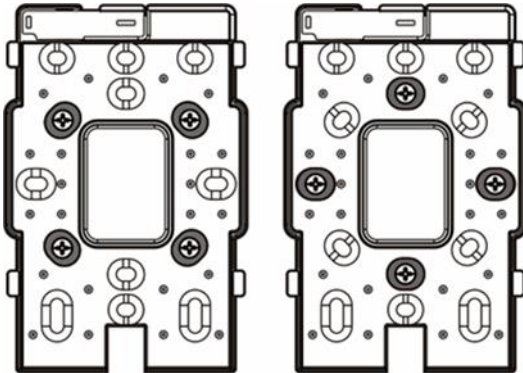

- o American-standard 108 mm x 59 mm junction box. Select two hole positions to install screws:

Note

If more than two screws are required, prepare them by yourself.

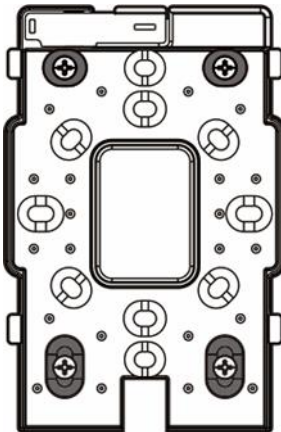

- o South African-standard 114 mm x 114 mm junction box. Select two hole positions to install screws:

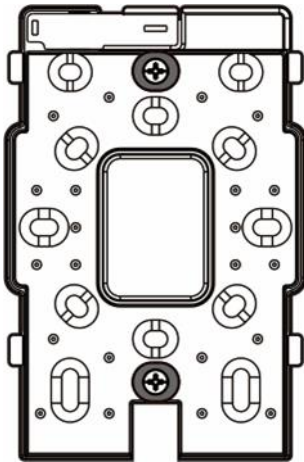

- (3) Connect cables according to the actual topology. Connect cables to ports of the AP.
- Ethernet cable: Connect one end of an Ethernet cable to the WAN/PoE port on the back of the AP. The port supports PoE In.
 - Ethernet cable: Connect one end of the Ethernet cable to one of LAN 1 to LAN 4 ports on the bottom of the AP. LAN 4 port supports PoE Output.

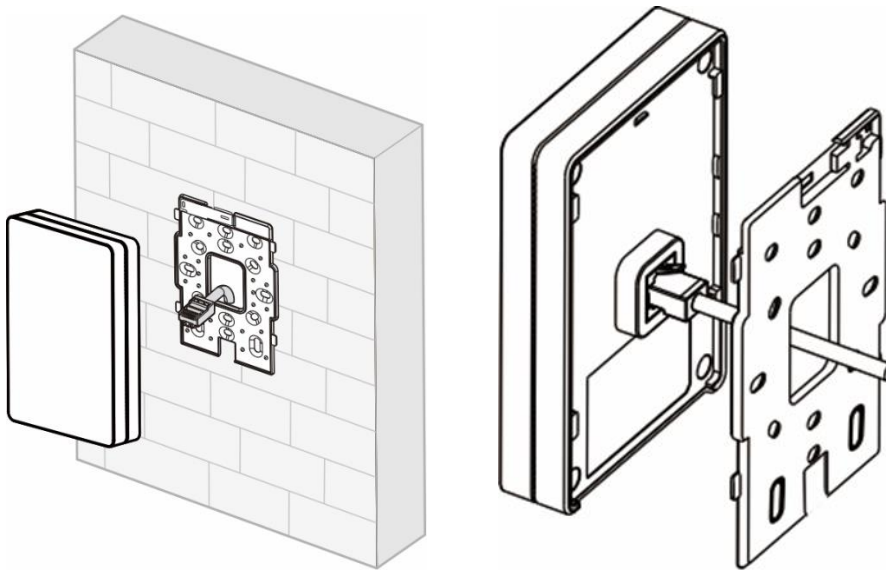

⚠ Caution

- Avoid a small bend radius at the connector.
 - To power the AP through PoE, ensure that the PSE connected to the WAN/PoE port of the AP complies with IEEE 802.3af or IEEE 802.3at. The PoE Out feature of the LAN 4 port is disabled when IEEE 802.3af is used.
-

- (4) Align the upper edge of the WAN port on the AP with the upper edge of the hole on the mounting bracket. Slide the device downward to secure it on the mounting bracket.

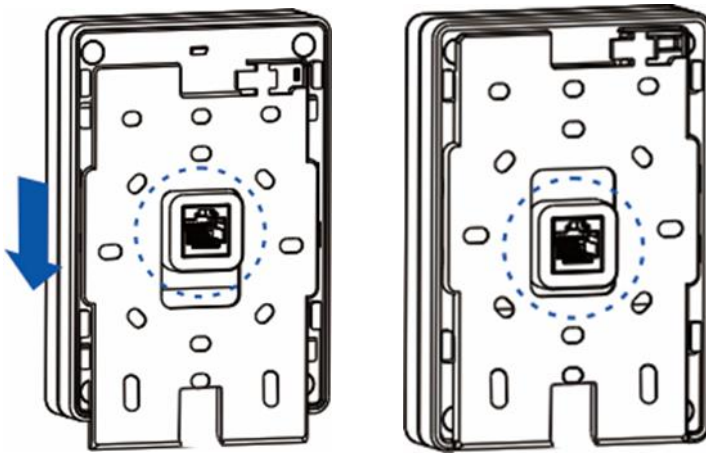

⚠ Caution

Keep the L-shaped key to the anti-theft lock after installation. This AP is designed with an anti-theft function. You need to use the key to remove the AP.

- (5) The installation is complete.

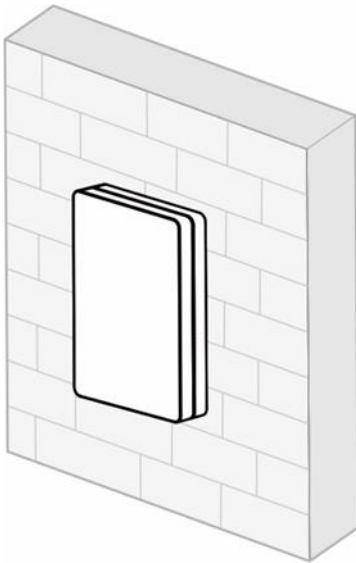

3.4 Removing the Equipment

- (1) Insert the L-shaped key into the reserved slot at the bottom of the AP and rotate the key to remove the decorative cover.

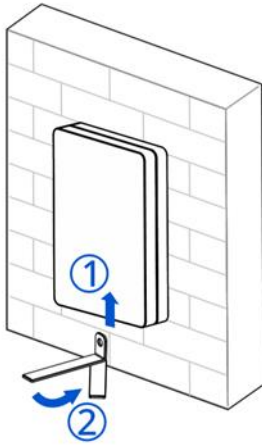

- (2) Insert the L-shaped key into the anti-theft lock slot on the top of the AP, and push the AP upwards to remove it.

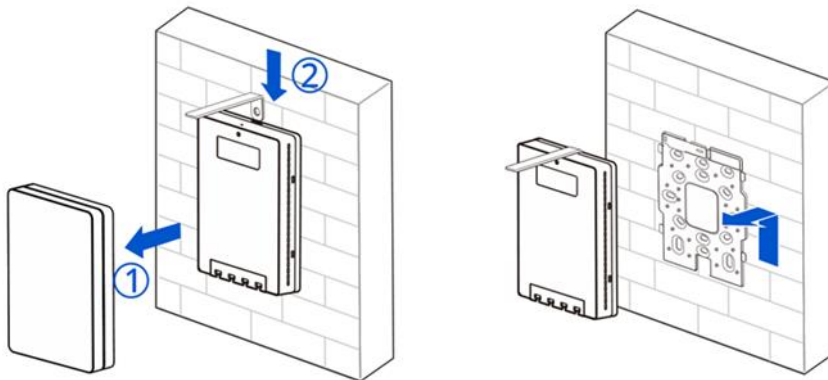

3.5 Bundling up Cables

Precautions

- Bundle cables in an aesthetically pleasing way.
- Ensure that the twisted pairs have natural bends or bends of large radius at the connectors.
- Do not bind twisted pair cables too tightly, as this may compromise their service life and transmission performance.

Bundling Steps

- (1) Bundle the drooping part of the cables and place the bundle as near the ports as possible.
- (2) Secure the cables in the cable management trough of the mounting bracket.
- (3) Route the cables under the AP and run them in a straight line.

3.6 Checklist After Installation

- (1) Check the AP.
 - The external power supply matches the requirements of the AP.

- The equipment is securely fastened.
- (2) Check the cable connections.
- Make sure that the twisted pairs match the port type.
 - Cables are properly bundled.
- (3) Check the power supply.
- The power cord is properly connected and meets the safety requirements.
 - The AP is operational after power-on.

4 Verifying Operating Status

4.1 Setting Up the Configuration Environment

When the AP is powered on through PoE, pay attention to the following:

- Verify that the power cord is properly connected and compliant with safety requirements.
- Connect the AP to the debugging equipment using an Ethernet cable.

4.2 Powering on the AP

4.2.1 Checklist Before Power-on

- Verify that the power cord is properly connected.
- Check if the PSE connected to the WAN/PoE port complies with IEEE 802.3af or IEEE 802.3at.

4.2.2 Checklist After Power-on

- Verify the LED status.
- After the AP is powered on, check whether the SSID (@Ruijie-mXXXX for multiple devices and @Ruijie-sXXXX for a single device) can be detected by a mobile phone or other wireless clients.

4.3 Rectifying Power Supply Failures

You can determine whether a power system failure exists by checking the LED status on the front panel of the AP. For details about the working status of the LED, see [Table 1-3 LEDs](#). Perform the following checks if the power supply is not functioning properly.

- Check whether the equipment is properly powered.
- Check whether the Ethernet cable is properly connected.

Note

If the equipment cannot start after all the preceding items are verified, contact your local distributor or technical support.

5 Monitoring and Maintenance

5.1 Monitoring

When the RG-RAP62-Wall is operating, you can monitor the equipment running status by observing the LED. For details about the working status of the LED, see [Table 1-3 LEDs](#).

5.2 Maintenance

If the hardware is faulty, contact your local distributor.

6 Common Troubleshooting

6.1 General Troubleshooting Flowchart

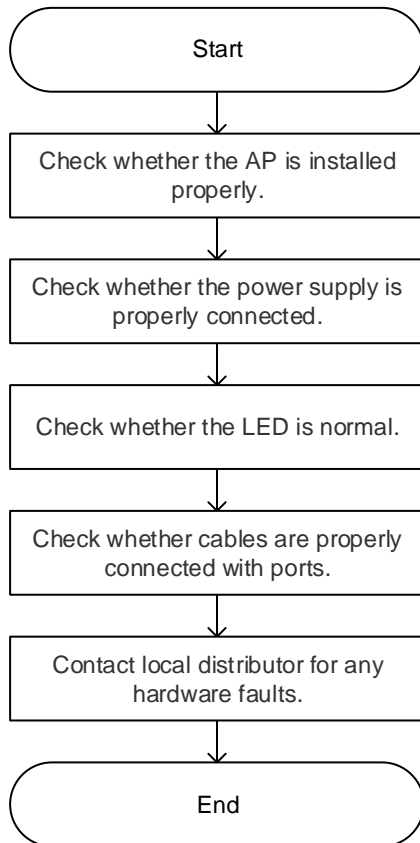

Start	
Check whether the AP is installed properly.	
Check whether the power supply is properly connected.	
Check whether the LED is normal.	
Check whether cables are properly connected with ports.	
Contact local distributor for any hardware faults.	
End	

6.2 Common Faults

- Why is the LED off after the equipment is powered on?
Verify that the PSE connected to the AP is compliant with IEEE 802.3af or IEEE 802.3at, and that the Ethernet cable is properly connected.
- Why does the Ethernet port fail to work after the Ethernet cable is connected to it?
Verify that the peer equipment is working properly. Then, verify that the Ethernet cable is capable of providing the required data rate and is properly connected.
- Why can't clients discover the AP?
 - Verify that the equipment is properly powered.
 - Verify that the Ethernet port is correctly connected.
 - Check whether the AP is correctly configured.
 - Move the client to adjust the distance between it and the AP.
- The PoE Out function of the LAN 4 port is disabled.
 - Verify that the PSE is compliant with IEEE 802.3at or supports the same power supply rating.
 - If the PSE meets power supply requirements, log in to the device's eWeb, and choose **Advanced > PoE Settings** to check whether **Power Mode** is set to **IEEE 802.3af**. If so, change it to **IEEE 802.3at**.

7 Appendix

7.1 Connectors and Media

7.1.1 10/100/1000BASE-T Port

The 10/100/1000BASE-T port supports three rates with auto-negotiation, and supports the automatic MDI/MDIX crossover function at these three rates.

Compliant with the IEEE 802.3ab standard, a 1000BASE-T port requires 100-ohm Category 6 or 5e unshielded twisted pair (UTP), or shielded twisted pair (STP) (recommended) cables, and supports a maximum distance of 100 meters (328 feet). When a PoE power supply is used, Category 6 STP cables are recommended, and both the port and the cable should be properly shielded.

The 1000BASE-T port requires all four pairs of wires to be connected for data transmission. [Figure 7-1 Connections of Four Twisted Pairs](#) shows twisted pair connections for the 1000/2500BASE-T port.

Figure 7-1 Connections of Four Twisted Pairs

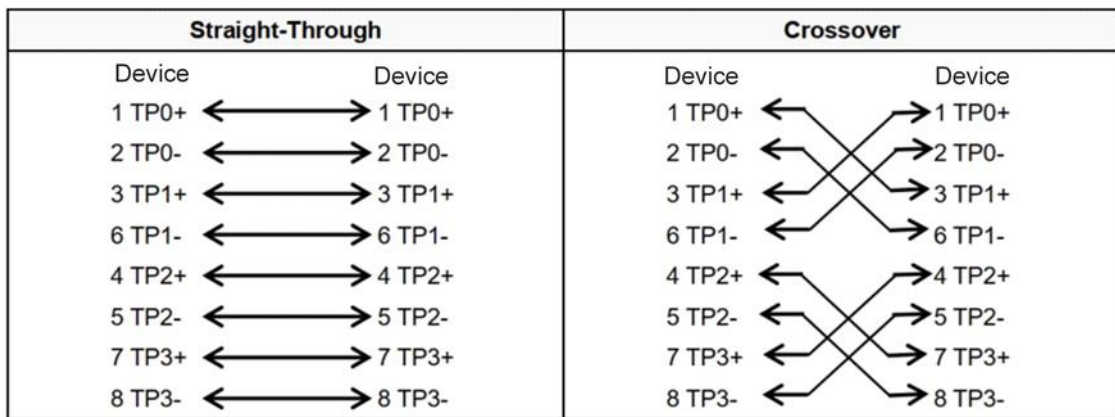

Straight-Through	
Crossover	
Device	

The 10/100BASE-T port can also be connected by cables of the preceding specifications. Besides, the 10BASE-T port can be connected by 100-ohm Category 3, Category 4, and Category 5 cables with a maximum distance of 100 meters (328.08 feet). The 100BASE-TX port can be connected by 100-ohm Category 5 cables with a maximum distance of 100 meters (328.08 feet). The following table lists pin assignments for the 10/100BASE-T port.

Table 7-1 10/100BASE-T Pin Assignments

Pin	Socket	Plug
1	Input Receive Data+	Output Transmit Data+
2	Input Receive Data-	Output Transmit Data-
3	Output Transmit Data+	Input Receive Data+
6	Output Transmit Data-	Input Receive Data-
4, 5, 7, 8	Not Used	Not Used

The following figure shows feasible connections of the straight-through and crossover twisted pairs for a 10/100BASE-T port.

Figure 7-2 10/100BASE-T Twisted Pair Connections

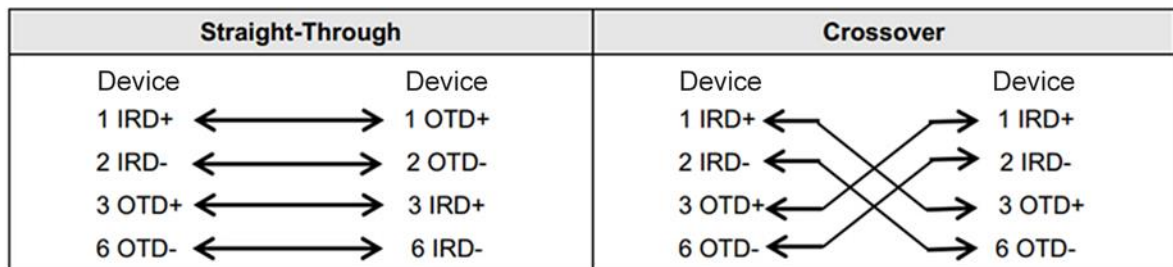

7.2 Cabling Recommendations

When installing the RG-RAP62-Wall, route the cables through the cable management brackets. Top cabling or bottom cabling is adopted according to the actual situation in the equipment room. All adapted connectors should be placed at the bottom of the rack in an orderly manner instead of outside the rack that is easy to touch. Power cords are routed beside the rack. Top cabling or bottom cabling is adopted according to the actual situation in the equipment room, such as the positions of the DC power distribution box, AC socket, or lightning protection box.

Requirements for the Minimum Bend Radius of Cables

- The bend radius of a fixed power cord, Ethernet cable, or flat cable should be over five times greater than their respective external diameters. The bend radius of these cables that are often bent or plugged should be over seven times greater than their respective external diameters.
- The bend radius of a fixed common coaxial cable should be over seven times greater than its external diameter. The bend radius of these cables that are often bent or plugged should be over 10 times greater than their respective external diameters.
- The minimum bend radius of a high-speed cable, such as an SFP+ cable, should be over five times greater than its external diameter. The bend radius of these cables that are often bent or plugged should be over 10 times greater than their respective external diameters.

Precautions for Cable Bundling

- Before cables are bundled, mark labels and stick the labels to cables wherever appropriate.
- Cables should be neatly and properly bundled in the rack without twisting or bending, as shown in [Figure 7-3](#).

Figure 7-3 Bundling up Cables (1)

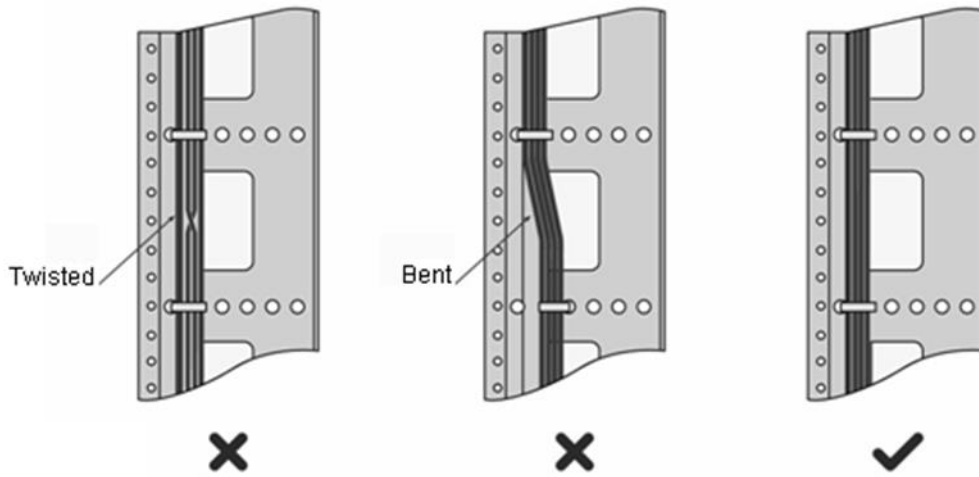

Twisted	
Bent	

- Cables of different types (such as power cords, signal cables, and grounding wires) should be separated in cabling and bundling. Mixed bundling is disallowed. When they are close to each other, you are advised to adopt crossover cabling. In the case of parallel cabling, maintain a minimum distance of 30 mm (1.18 in.) between power cords and signal cables.
- The cable management brackets and cabling troughs inside and outside the rack should be smooth without sharp corners.
- The metal holes traversed by cables should have a smooth and fully rounded surface or an insulated lining.
- Use cable ties to bundle up cables properly. Please do not connect two or more cable ties to bundle up cables.
- After bundling up cables with cable ties, cut off the remaining part. The cut should be smooth and trim without sharp corners, as shown in [Figure 7-4](#).

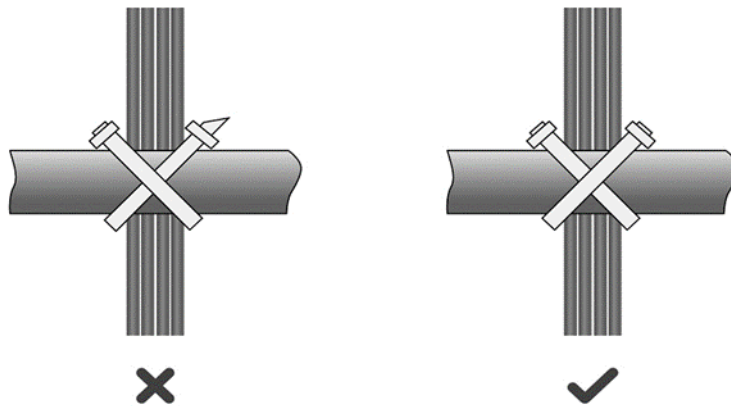
Figure 7-4 Bundling up Cables (2)

- When cables need to be bent, bundle them first but do not tie cables within the bend. Otherwise, stress may be generated on the cables and cause the wires inside to break, as shown in [Figure 7-5](#).

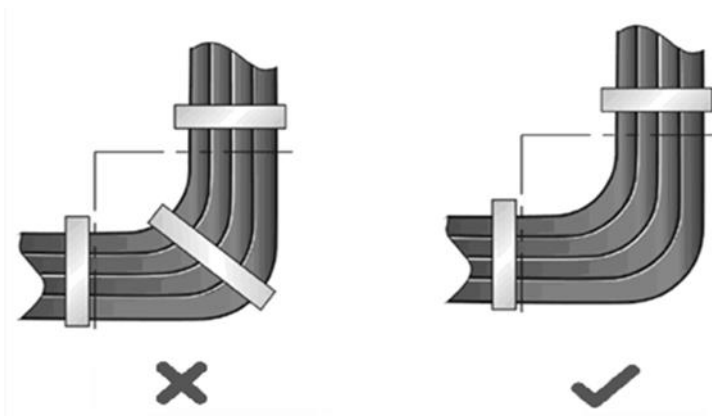
Figure 7-5 Bundling up Cables (3)

- Cables not to be assembled or the remaining parts of cables should be folded and placed in a proper position of the rack or cable trough. The proper position refers to a position that does not affect the equipment running or damage the equipment or cables.
- 220 V and -48 V power cords must not be bundled on the guide rails of moving parts.
- The power cords connecting moving parts such as door grounding cables should be reserved with some excess after being assembled. This can avoid tension or stress on power cords. After the moving part is installed, the remaining cable part should not touch heat sources, sharp corners, or sharp edges. If heat sources cannot be avoided, high-temperature cables should be used.
- When using screw threads to secure a cable lug, ensure that the bolt or screw is properly tightened and take measures to prevent it from loosening, as shown in [Figure 7-6](#).

Figure 7-6 Fastening Cable Lugs

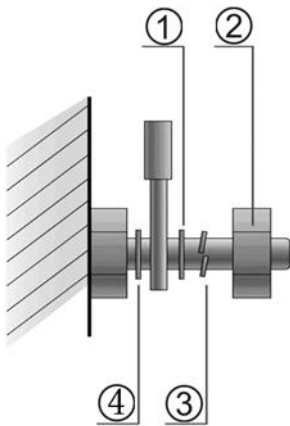

Note:	1. Flat washer	3. Spring washer
	2. Nut	4. Flat washer

- Hard power cords should be fastened in the terminal connection area to prevent stress on the terminal connection and cable.
- Do not use tapping screws to secure cable lugs.
- Power cords of the same type and in the same cabling direction should be bundled up into cable bunches, with cables in cable bunches clean and straight.
- Bundle up cables by using cable ties according to the following table.

Cable Bunch Diameter	Distance Between Every Binding Point
10 mm (0.39 in.)	80 mm to 150 mm (3.15 in. to 5.91 in.)
10 mm to 30 mm (0.39 in. to 1.18 in.)	150 mm to 200 mm (5.91 in. to 7.87 in.)
30 mm (1.18 in.)	200 mm to 300 mm (7.87 in. to 11.81 in.)

- Do not tie cables or bundles in a knot.
- For wiring terminal blocks (such as circuit breakers) with cord end terminals, the metal part of the cord end terminal should not be exposed outside the terminal socket when assembled.